

Activity 1: Apple and Ocean

Overview

Our world is a water planet; nearly three-fourths of the Earth's surface is covered by ocean. Looking at a globe from the perspective of the vast Pacific Basin, it appears obvious that Planet Earth should more appropriately be named "Planet Ocean"!

The ocean allows life to exist. It makes our climate habitable, provides much of our oxygen and food, and transports—among much else—nutrients, people, and (sadly) even pollution around the globe. While the ocean may seem a limitless resource, only a small fraction is considered even moderately biologically productive. **Nearly all the marine resources we depend on come from a few small regions of the total ocean.**

In this activity, students are introduced to the vastness of our planet's one, interconnected ocean, and to the importance of the ocean to all life on Earth. They're also introduced to the concept of the very limited resources we depend on from the land (habitable area, farmable land, and fresh water) and from the ocean (upwelling areas that allow high biological productivity).

In Session 1, students get "**Into** the Activity" by brainstorming what they know, value, and enjoy about the ocean. They go on to reflect on the benefits of the ocean to human life, and discover where most of life is found in the ocean. The class then goes "**Through** the Activity" over the next two sessions. In Session 2, students work in pairs, using an apple and a circle graph to represent the planet. To understand the intangible concept of limited land and water resources, students carefully section the apple and the graph into wedges representing various critical resources on the planet. These visuals give students an immediate sense of the small proportion of the Earth that provides resources from the land and the ocean.

In Session 3, students design a mini-book, journal entry, or other creative writing piece to demonstrate what they've learned. A number of "Going Further" activities are suggested for going "**Beyond** the Activity."

When people say "the Earth," they often mean just the land portion of the planet. Of course Earth also means the entire planet—made up of land, ocean, and atmosphere. If we consider all of the planet, then much of it is in fact made up of "earth" (sand, rocky soil, mountains, the molten rock below the surface, mantle, core, etc.). But if we consider only the surface of the Earth, then the ocean represents by far the largest proportion.

Benchmarks for Science Literacy emphasizes the need for students to better understand and appreciate the global food web of which they are a part. The fragile resources of the ocean play a critical role in supporting life on our planet.

To help students who may have trouble understanding fractional parts, a number line can be a helpful representation (see page 160).

What You Need

For the class:

- a large (36") inflatable globe (available in many travel stores and children's stores)
- pictures from magazines, old calendars, or postcards depicting the ocean or ocean life
- up to 7 sheets of chart paper (approximately 27" x 34", to record brainstorming and display Key Concept)
- 1 "Land" poster or overhead transparency (example on page 17)
- 1 "Ocean" poster or overhead transparency (example on page 17)
- a roll of masking tape
- (*optional*) an overhead projector (if you don't use chart paper for brainstorm)
- (*optional*) up to 7 blank overhead transparencies
- (*optional*) 1 audiocassette player
- (*optional*) 1 audiocassette of natural ocean sounds
- (*optional*) laminated posters depicting physical or biological aspects of productive coastal zones (see "Resources," page 163)
- (*optional*) 1 large world map

For each pair of students (plus one extra for the teacher):

- 1 apple
- 1 butter knife (metal preferred, or VERY sturdy plastic)
- 1 full-sized, round, white, undivided, sturdy paper plate (Chinet® or similar)
- 1 set of colored markers (wide-tipped, water-based)
- 1-2 paper towels

For each student:

- notepaper for brainstorming
- 1 sheet of 10" x 14" or 11" x 17" blank paper for mini-book
- lined paper or journals for creative writing
- a few fine-point markers
- 1 pair of scissors

Getting Ready

1. On chart paper, create two blank Brainstorm Charts (one for Session 1, one for Session 2). (You may wish to make a separate Question Chart as well, to record any questions that arise during the brainstorm.) Post the charts at the front of the room.
2. After reading the Apple and Ocean overview, read the Brief Introduction to Upwelling on page 32 and decide if you'll present this as a separate activity.
3. Have ready the large inflatable globe and the ocean posters (if you've decided to use them).
4. Make and hang the "Land" and "Ocean" posters at the front of the room where you can easily write on them, or create and set up the transparencies on the overhead projector. (It's a nice touch to add small drawings, as shown in the illustration below.)

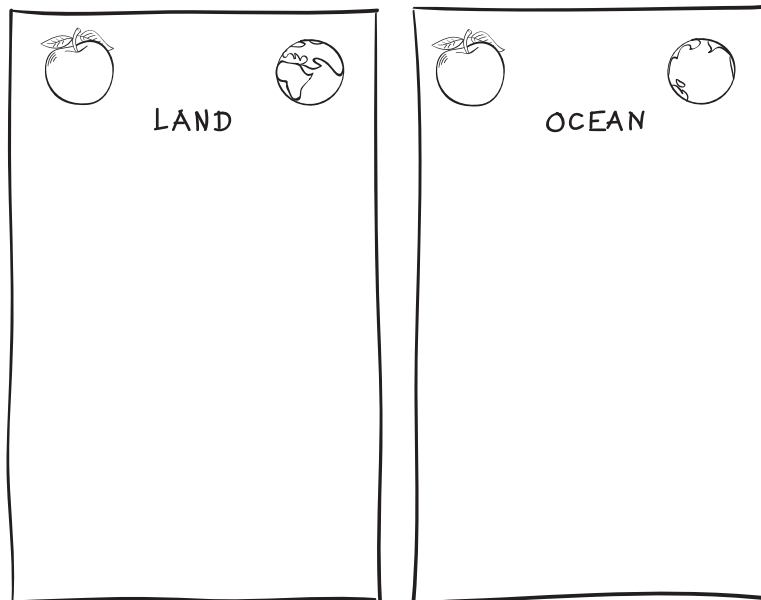
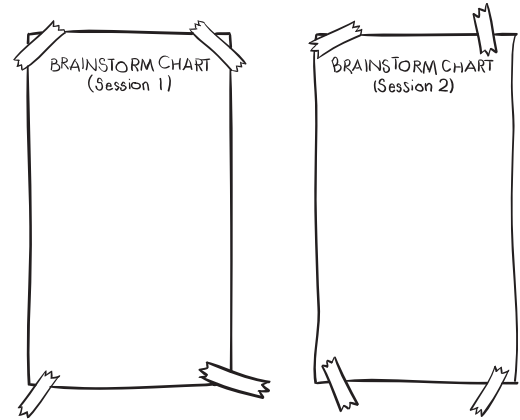

5. Write out the Key Concept for this activity in large, bold letters on a half-sheet of chart paper, and set aside:

- **Most of our planet is covered by ocean, but only a small fraction of the ocean supports large concentrations of life.**

6. Buy and wash the apples (students may want to eat them at the end). We recommend soft apples like red delicious or golden delicious (not pippins) that will cut easily.

Using apples to represent our planet is an effective and hands-on way for students to get a sense of the limited resources our world supports. At the end of the activity, if students don't wish to eat the apples, have them brainstorm ways in which they can be recycled or reused.

To better understand “where you’re going” with this activity, see the completed circle graph on page 30.

ABOUT THE OCEAN

- a. What do you know and enjoy about the ocean?
- b. How do people depend on the ocean?
- c. What are the things people do that affect the ocean and the life that lives there?
- d. What areas of the ocean do you think contain the most life?
- e. Where do you think the best spots are in the ocean to catch fish?

7. Read through all the sessions, especially Session 2: Apple and Ocean. In this session, you’ll guide your students through a series of apple slicing and charting activities. The steps may seem a bit stiff at first, but they outline the “flow” of slicing and recording. The process will move quickly as you become accustomed to the back-and-forth nature of the activity. As the slicing progresses, your students will be amazed at the tiny pieces that represent fresh water and habitable land.

8. If you’ve decided to use them, set up the ocean-sounds audiocassette and cassette player. Gather the ocean pictures and photos for the brainstorm. Write the following questions on chart paper, the board, or an overhead transparency:

- a. What do you know and enjoy about the ocean?
- b. How do people depend on the ocean?
- c. What are the things people do that affect the ocean and the life that lives there?
- d. What areas of the ocean do you think contain the most life?
- e. Where do you think the best spots are in the ocean to catch fish?

9. Decide how you’ll divide students into the pairs and small groups needed for this activity, and have all materials at the ready.

*Ocean Literacy Principle 6:
The ocean and humans
are inextricably intercon-
nected.*



Session 1: Brainstorm—Our “Planet Ocean”

1. Tell the class they’re about to study the ocean. Explain that when you say “the ocean,” you mean the planet’s one, vast ocean—not just the Atlantic, Pacific, Indian, etc. Arrange students in groups of four or six. Pass out the pictures and photos and play the ocean-sounds cassette. Ask students to discuss the questions you’ve posted, encouraging them to use the pictures to help them brainstorm.

2. Tell them that as they talk, they might come up with questions about the ocean. Have them jot these down on paper for later reference. Circulate among the groups to encourage discussion and to listen to their ideas.

3. After a few minutes, invite the groups to share their brainstorm ideas and questions. Refer back to the original

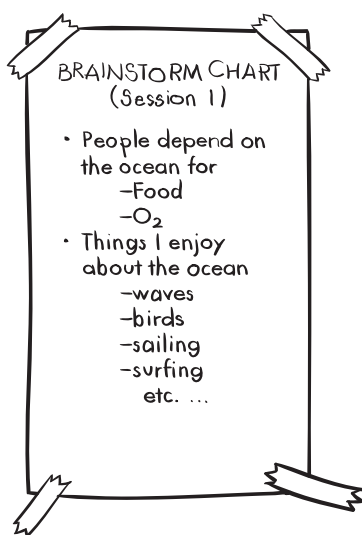

posted questions to get the sharing going. Make sure each group gets a chance to share a few thoughts or questions, and record these on the Brainstorm Chart for Session 1.

4. Pull out the globe and show the class the “traditional map view” of the world—that is, with the continents in full view with the Americas in the center. Ask the students what they can tell about the world from this perspective. [Big continents of land surrounded by water.] Now, turn the globe to show the “Pacific Ocean view.” What does *this* view tell about the world? [Most of the Earth is covered by ocean!]

5. Lead a brief discussion, based on this new perspective and the ideas brought up in the brainstorm, to introduce these important concepts:

- Most of our planet is covered by ocean.
- About 95 percent of all *living space* on the planet (for all organisms) is located in the ocean.
- About 85 percent of everything that lives on Earth lives in the ocean.
- About 70 percent of the oxygen we breathe comes from the process of photosynthesis by microscopic plantlike organisms, or *phytoplankton*.
- People get food and water from the ocean.
- The ocean plays a major role in moderating our climate. Without an ocean, the surface of our planet would freeze at night and be too hot for most life to endure during the day.

The ocean was the blue part of the globe with lines and letters on it.

—from “Earliest Memories of the Ocean,” MARE Summer Institute, 1994

The vast expanse of ocean water is less changeable than land; it acts as a heat “sink” at night, keeping the planet from freezing. During the day, in certain areas, winds sweeping over the ocean pick up air evaporated from cold ocean currents and carry it over the land, keeping the planet cool.



Session 2: Apple and Ocean

1. Tell students they’re going to discover even more about the critical resources we depend on from “Planet Ocean.” Hold up an apple and explain how they’ll use this model to better understand the limited resources available on our planet. To help students see the activity as more than just an apple-cutting experience, tell them scientists often use a smaller model to help explain ideas about something too large to work with—in this case, our planet!

2. Have students clear all materials off their tables and sit side by side with a partner. Pass out to each pair an apple, a knife, a paper plate, a paper towel, and a set of colored markers. Keep a complete set for yourself to demonstrate with. Ask students to be careful with the knives, and **not to make any cut until after you’ve demonstrated it.**

Ocean Literacy Principle 1: The ocean, which covers 70% of Earth’s surface, is the defining feature of the planet.

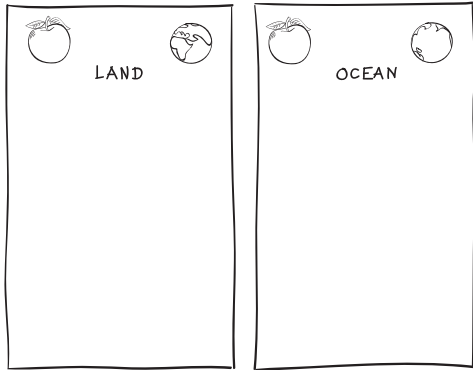

The content you'll present with the cutting of the apple is fairly complex and moves fairly quickly, so it's especially important for English-language learners that you establish a consistent "rhythm" with the sequence. Students will soon become aware that there are several opportunities to understand each "fact" (see you cut it, cut it themselves, hear you say it, see you and their partner graph it, see you write it on the poster). This should help lower their anxiety.

7th- and 8th-grade teachers have suggested eliminating the teacher demonstration of the circle graph throughout the lesson, to allow students to do it on their own without the prompts. (Read ahead to eliminate your involvement in this step if that's what you decide.) Alternatively, teachers have used the circle graph activity as a separate assessment activity following this lesson.

3. Hold up an apple and the globe, point to the "Land" and "Ocean" posters or transparencies, and again tell the students they'll be using the apple as a model to represent the planet.

4. Have them quickly decide (or you can assign) which partner will be the "land" person and which will be the "ocean" person. (Let them know they'll switch jobs half-way through the activity.) Have the land people raise their hands, and tell them that they should start with the apple, the knife, and a paper towel to cut on.

5. Have the ocean people raise their hands, and tell them that they should start with the plate and the markers. Explain that the land people are going to make some cuts on the apple, and the ocean people will make a circle graph to represent each of those cuts.

6. Explain that you'll demonstrate each step before students do it themselves. Students will hold up their apple slices and graphs after each step, so that you and their partners can check them for understanding.

7. Again, show the "Land" and "Ocean" posters at the front of the room or on the overhead projector. Tell the students you'll also record information here for everyone to see.

For each slice of the apple, you'll go through the following sequence:

1. **Teacher gives a direction** about how to cut the apple.
2. **Teacher cuts the apple** to demonstrate.
3. **"Land people" students cut the apple** and hold up the piece. Teacher asks students what part of the planet this represents.
4. **Teacher explains** the significance of the fractional part of the planet this slice represents and, when applicable, shows its corresponding part on the globe.
5. **Teacher draws a corresponding section on the circle graph** to demonstrate. (This step is optional—we suggest you read both sidebars before deciding.)
6. **"Ocean people" students draw a corresponding section on their circle graphs** and hold them up.
7. **Teacher writes and labels** the fraction on the poster or transparency.

Slice One: $\frac{1}{4}$ of the Planet is LAND

1. Teacher gives direction and cuts the apple.

Tell the land people that they're going to cut the apple into four equal pieces by cutting it in half through the core and cutting each of those halves in half again. Cut your apple to demonstrate.

2. Students cut the apple.

Have students cut their apples and hold up one of the four pieces when they're finished. Ask them, "What fractional portion of the planet does this represent?" [$\frac{1}{4}$.]

3. Teacher explains.

Explain that this section of apple represents $\frac{1}{4}$ of the planet, the portion that is covered by *land*. Show this on the globe. The other three sections represent the $\frac{3}{4}$ of the world covered by *ocean*; have students set those three pieces aside for the ocean part of the activity.

4. Teacher draws on the circle graph.

a. Tell the ocean people they're going to use their plates to make a circle graph representing the ocean and land portions of the planet. Ask students how to divide the plate into these fractional parts.

b. Demonstrate as necessary, holding up your plate and drawing with a colored marker. First draw a line (diameter) from one point on the circumference of the plate to a point on the opposite side (going through the center point), to divide the plate in half. Draw a second diameter, perpendicular to the first, to divide the plate into fourths.

c. Model one way to label the circle graph: On the rim of the plate, label each of three fourths "ocean" and the remaining fourth "land."

5. Students draw on the circle graph.

Have students create their graphs. Circulate among them and assist any students who are having difficulty.

6. Teacher writes on the poster or transparency.

At the top of the "Land" poster or transparency, under LAND, write " $\frac{1}{4}$ Land."

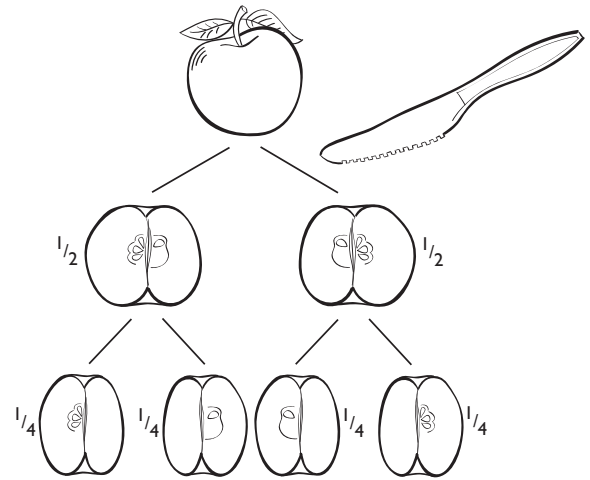

You may wish to have students place their apple slices on a piece of paper, after they've cut them, and label each section (fractional part) to refer to later.

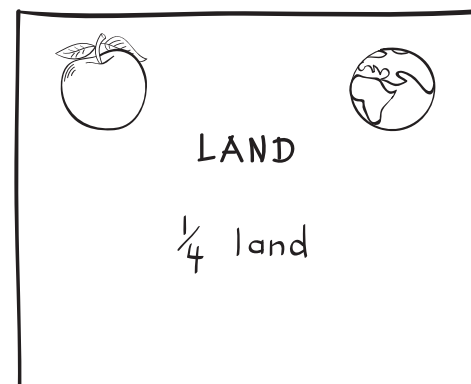
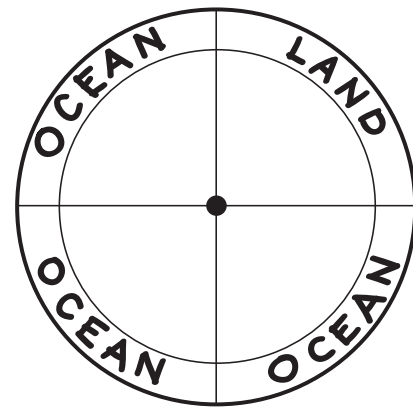

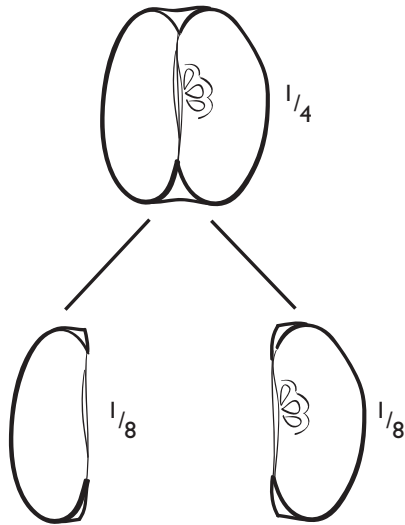

Slice Two: $\frac{1}{8}$ of the Planet is Uninhabitable Land

1. Teacher gives direction and cuts the apple.

Tell the land people they're going to cut the piece of the apple representing the land into two equal pieces. Divide your $\frac{1}{4}$ piece, either lengthwise or across the widest section. Hold up the two slices and demonstrate that they're equal.

2. Students cut the apple.

Have students cut their apple fourths into two equal pieces and hold up one of the resulting slices. Ask them, "What fractional portion of the planet does this represent?" [$\frac{1}{8}$.]

3. Teacher explains.

Explain that this piece represents all the land on Earth that's too dry, too wet, too cold, or too hot for people to live on. This is *uninhabitable* land, such as many mountain tops, river basins, deserts, etc. Show a few examples on the globe.

4. Teacher draws on the circle graph.

- Tell the ocean people they're going to draw the uninhabitable portion of the land on the circle graph. Have them locate the land on their plates. How might they divide it?
- Demonstrate how to draw a line (radius) from the center point of the plate to the rim, dividing the $\frac{1}{4}$ land into two equal pieces.
- Model how to label one of the $\frac{1}{8}$ portions of the circle graph with a picture of a frowning person inside a red circle with a line through it. This represents the "uninhabitable" portion of the land.

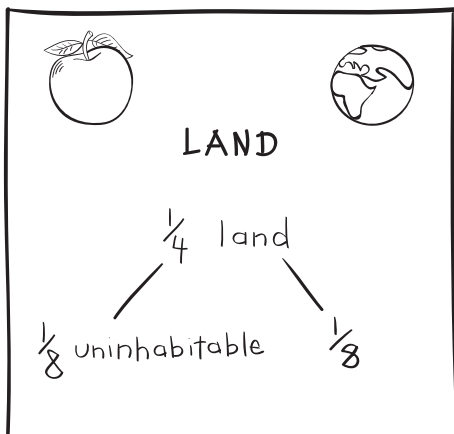
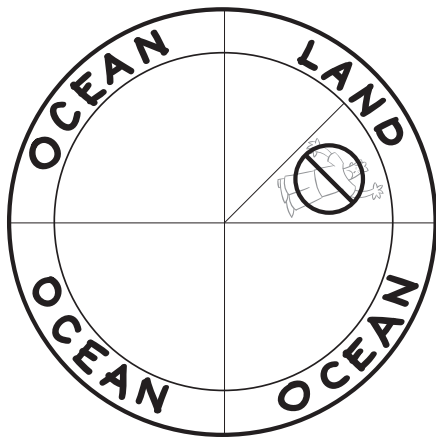

5. Students draw on the circle graph.

Have students record on their graphs. Walk around holding yours up and assist students as necessary.

6. Teacher writes on the poster or transparency.

On the poster or transparency, under $\frac{1}{4}$ Land add a branch labeled " $\frac{1}{8}$ Uninhabitable."

Slice Three: $\frac{1}{8}$ of the Planet is Habitable Land

1. Teacher explains and draws on the circle graph.

Tell land students to follow along as you set aside the $\frac{1}{8}$ of your apple representing the uninhabitable land. Hold up the remaining $\frac{1}{8}$ piece of apple and have the students do the same. Ask them, "What fractional portion of the planet does this represent?" Explain that it represents the *habitable* land (where people *can* live). Show a few examples on the globe. Now hold up your plate and label this $\frac{1}{8}$ of the graph "habitable" by drawing a picture of a person smiling.

2. Students draw on the circle graph.

Have ocean people do the same on their graphs.

3. Teacher writes on the poster or transparency.

On the poster or transparency, next to $\frac{1}{8}$ Uninhabitable add a branch labeled " $\frac{1}{8}$ Habitable."

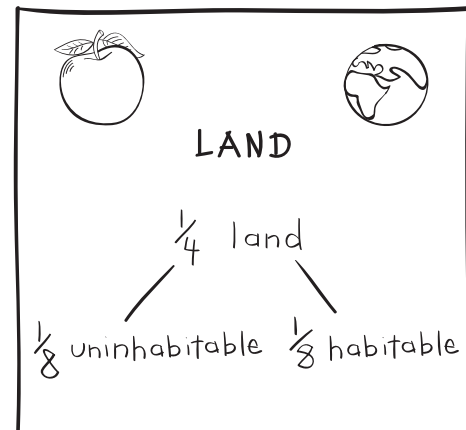
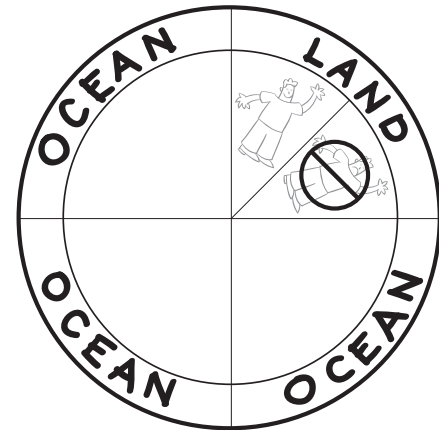

Slice Four: $\frac{1}{32}$ of the Planet is Farmable Land

1. Teacher gives direction and cuts the apple.

Demonstrate how to divide the $\frac{1}{8}$ piece representing the habitable land into four equal pieces, as follows:

- a. Cut the $\frac{1}{8}$ section into two equal pieces. Hold up one of these pieces and ask students, "What fractional portion of the planet does this represent? [$\frac{1}{16}$.]"
- b. Still holding up the $\frac{1}{16}$ piece, ask, "If we cut *this* piece into two equal pieces, what fractional part will we have? [$\frac{1}{32}$.]" Cut the $\frac{1}{16}$ section into two equal pieces. Repeat with the other $\frac{1}{16}$ section.

2. Students cut the apple.

Have students divide their $\frac{1}{8}$ piece into four equal pieces, as you did. As they hold up one of these pieces after cutting the apple, ask them, "What fractional portion of the planet does this represent?" [$\frac{1}{32}$.]"

3. Teacher explains.

This small fractional piece represents all the farmable land that grows food for people, as well as all the pasture and graze land that grows food for animals that then become food for people. Alarming, much of our farmable land in the U.S. is paved over each year to build towns and highways. On the globe, show a few examples of existing farmable land, and of land that was farmable in the past but has since been developed.

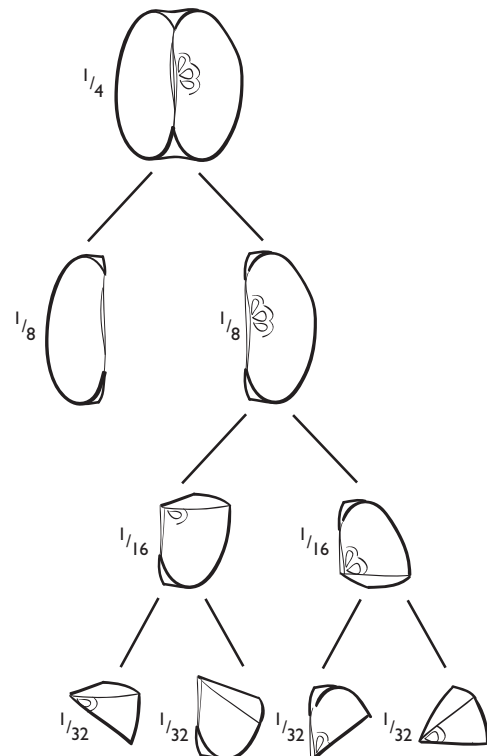

Most atlases can point you to specific regions where human development has altered the look and usability of the land over time.

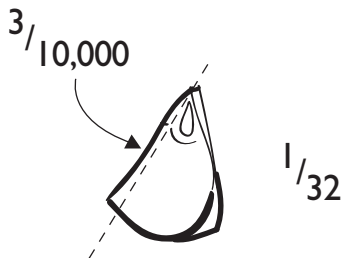
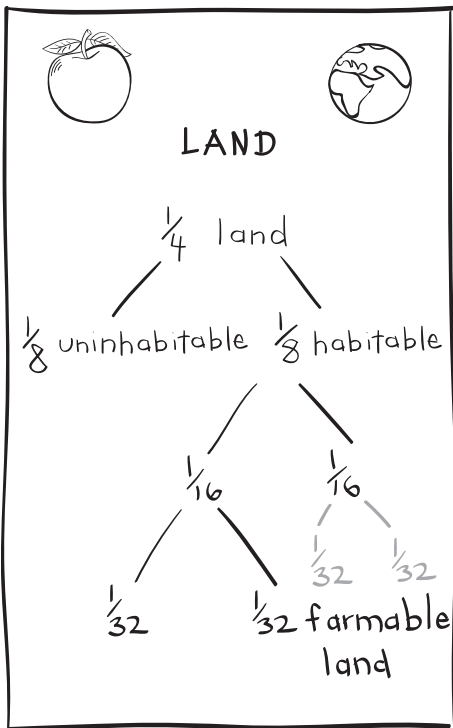
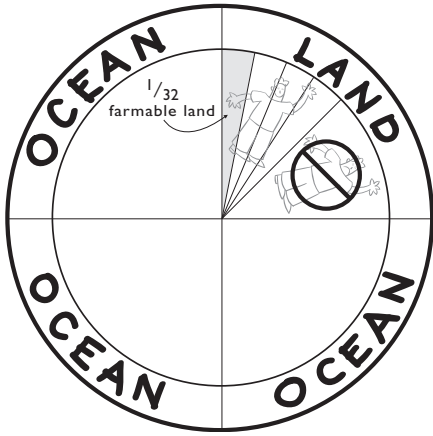

4. Teacher draws on the circle graph.

Divide the $\frac{1}{8}$ wedge representing the habitable land on the paper plate in half, then divide each of the resulting $\frac{1}{16}$ pieces in half again. Color one of the resulting $\frac{1}{32}$ pieces (ideally, green) to represent the habitable land on which we can grow food. With an arrow, label this colored slice " $\frac{1}{32}$ Farmable Land."

5. Students draw on the circle graph.

6. Teacher writes on the poster or transparency.

On the poster or transparency, under $\frac{1}{8}$ Habitable, add two branches labeled $\frac{1}{16}$. Under one of the $\frac{1}{16}$ branches, add two $\frac{1}{32}$ branches, and label one of them "Farmable Land."

Slice Five: $\frac{3}{10,000}$ of the Planet is Land with Drinkable Water

1. Teacher gives direction and cuts the apple.

Take the $\frac{1}{32}$ piece of the apple and (carefully!) cut off the thinnest, tiniest sliver possible and hold it up.

2. Students cut the apple.

Have students hold up their tiny slivers after cutting and ask them, "What fractional portion of the planet does this represent?" [It's so tiny that it's impossible to tell!]

3. Teacher explains.

This tiny sliver (still too big to reflect the actual proportions) is just a model that represents $\frac{3}{10,000}$ of the Earth's surface. This area supplies all the drinkable water on the planet (including both habitable and uninhabitable parts)! It represents all of our lakes, ponds, rivers, streams, reservoirs, and underground aquifers—all of the fresh water that is accessible to us. All life on land—every plant and animal, including every human—depends on fresh water for survival...and look how little of it there is! Show a few examples on the globe. Briefly discuss such water conservation issues as drought, pollution, water diversions, water use and waste, etc. Have students be sure not to lose this very important slice—you'll want to look at it again later.

4. Teacher draws on the circle graph.

Demonstrate how to represent the drinkable water on the plate using a few small dots (of a single color) in each of the land sections, both habitable and uninhabitable. (The number of dots doesn't matter.) Label these dots " $\frac{3}{10,000}$ Drinkable Water."

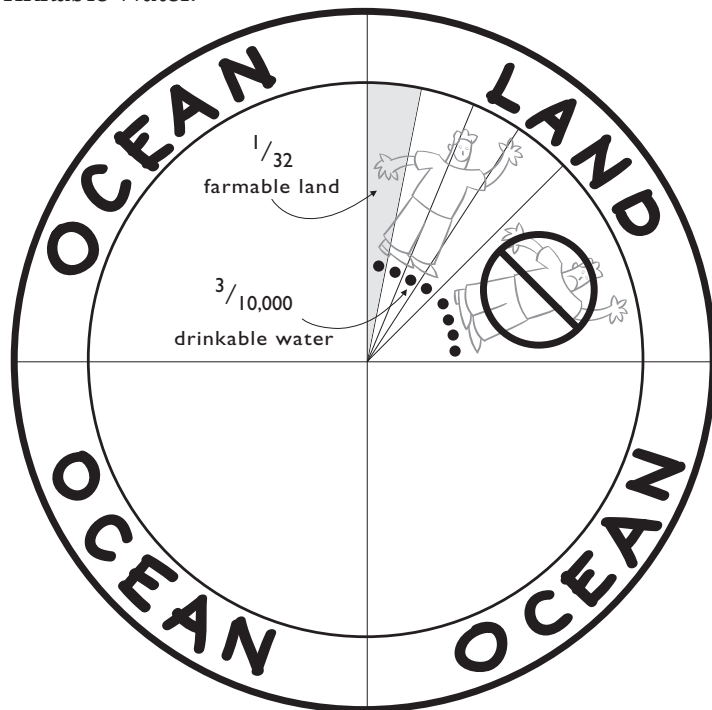

5. Students draw on the circle graph.

Have students record these dots on their graphs.

6. Teacher writes on the poster or transparency.

On the poster or transparency, under $\frac{1}{32}$ Farmable Land, add a branch labeled " $\frac{3}{10,000}$ Drinkable Water."

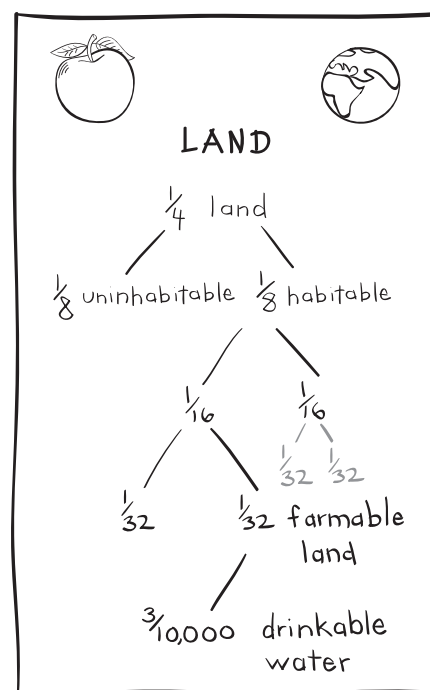

Slices Six and Seven:

$\frac{3}{4}$ of the Planet is OCEAN

Before continuing: Tell the class that now that they've seen how little fresh water there is on our planet, they're going to focus again on the ocean. Set aside the "land pieces" of the apple (**save the "drinkable water"!**), and return to the $\frac{3}{4}$ of the apple representing the ocean. **Have the partners switch jobs** so that the ocean partner is now cutting the apple and the land partner is now drawing on the paper plate. Call everyone's attention to the "Ocean" poster.

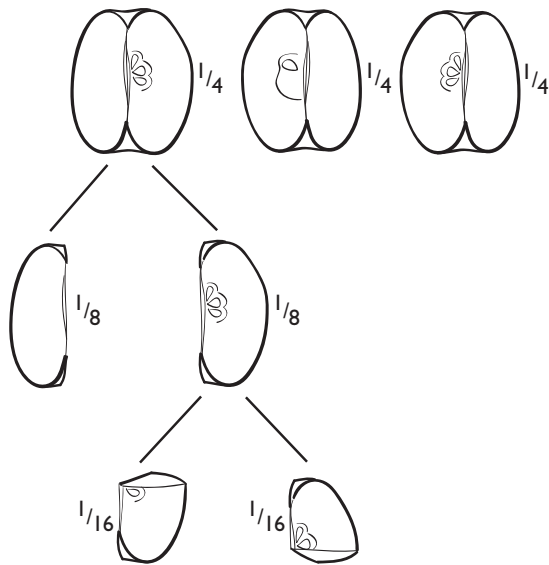

Although we think of the ocean as a vast, infinite resource, most regions of the world's ocean are not very productive; there's little life in these regions, and we consider them biological deserts. This little slice of apple represents the small region of the ocean considered even moderately productive. This area of concentrated ocean productivity is found over the shallow parts of the continental shelf. The shelf usually ends at 200 meters (660 feet) in depth and, on average, about 80 kilometers (50 miles) from shore (closer on the west coast of North America, farther on the east). The area of the planet's coastal zone is about four times the area of the lower 48 United States.

Slice Six: $\frac{1}{16}$ of the Planet is Productive Coastal Zone

1. Teacher gives direction and cuts the apple.

Tell the ocean people that they'll cut one of the three fourths that represents a portion of the ocean in half. Ask, "What fractional parts will those two pieces be?" [$\frac{1}{8}$.] Demonstrate the cut and hold up one of the $\frac{1}{8}$ pieces. Take that piece and cut it into two equal pieces. Hold up one of these small pieces and ask, "What fractional part of the planet does this represent?" [$\frac{1}{16}$.]

2. Students cut the apple.

Have students cut their apples and hold up one of the small pieces when they're finished. Review: "What fractional portion of the planet does this represent?" [$\frac{1}{16}$.]

3. Teacher explains.

Ask, "What kinds of things do we eat from the ocean?" [Fish, shrimp, clams, seaweed, etc.] "Where in the ocean do you think we harvest (catch) the most fish, shrimp, or clams?" Explain that the *fisheries* (commercial fishing operations) are located in these areas. This piece, $\frac{1}{16}$ of the planet's surface, approximately represents the biologically productive *coastal zones* of the ocean, where almost all (90%) of the world's fisheries occur. Looking at this fractional part, you can see that only a tiny portion of the ocean produces most of the seafood we eat! Show a couple of examples on the globe—perhaps off the west coasts of North America and Africa.

4. Teacher draws on the circle graph.

Demonstrate for the land people how to represent the productive coastal zone on the circle graph, before they follow along on theirs. Divide one of the fourths marked "ocean" in half. Then draw another line dividing one of these eighths in half to create sixteenths. Label one of the $\frac{1}{16}$ sections the "Productive Coastal Zone" and draw a fish or squid in it.

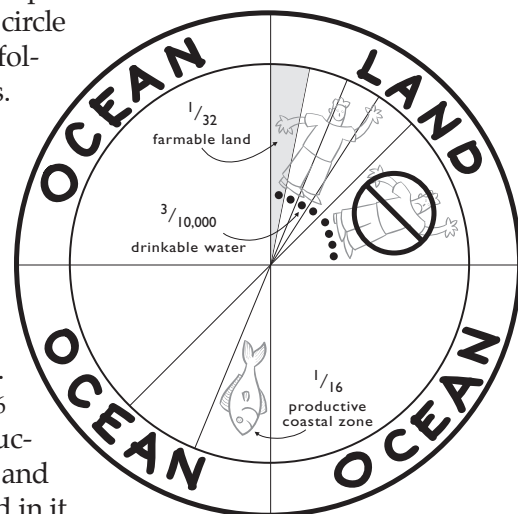

5. Students draw on the circle graph.

Have land people record the productive coastal zone on their graphs. Circulate among the students, holding up your graph and assisting as needed.

6. Teacher writes on the poster or transparency.

At the top of the "Ocean" poster or transparency, under OCEAN, write " $\frac{3}{4}$ Ocean." Under that, add branches for $\frac{1}{4}$, $\frac{1}{8}$, and $\frac{1}{16}$ as shown in the illustration. Label one of the $\frac{1}{16}$ branches "Productive Coastal Zone."

Slice Seven: $\frac{3}{4,000}$ of the Planet Is Upwelling Zone

1. Teacher gives direction and cuts the apple.

Take the $\frac{1}{16}$ piece of the apple. Cut off a very thin sliver and hold it up.

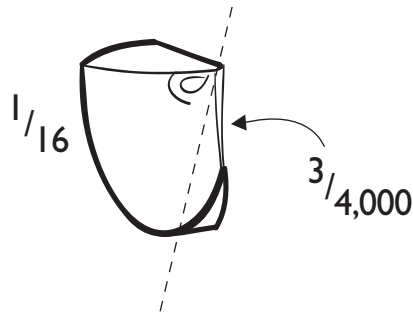

2. Students cut the apple.

Have students cut a sliver off one of their $\frac{1}{16}$ pieces. As they hold them up, ask, "What fractional portion of the planet does this represent?" [Again, it's so tiny that it's impossible to tell!] Ask them not to lose this sliver.

3. Teacher explains.

This tiny slice (which, like the drinking-water slice, is still too big to be anything but representative) is a model that represents $\frac{3}{4,000}$ of the world's surface. It represents the six tremendously productive *upwelling* areas found within the coastal zone. Explain that upwelling is a process that brings very cold, nutrient-rich water from deep down in the ocean up to the surface during some seasons on the west coasts of six continents. Show a few examples on the globe (see number 4, below). The highest concentrations of productivity are found in upwelling areas—these, as well as the polar areas in summer, are by far the most productive areas of the world's ocean. They're the prime destinations for migrating birds and marine mammals such as seals and whales.

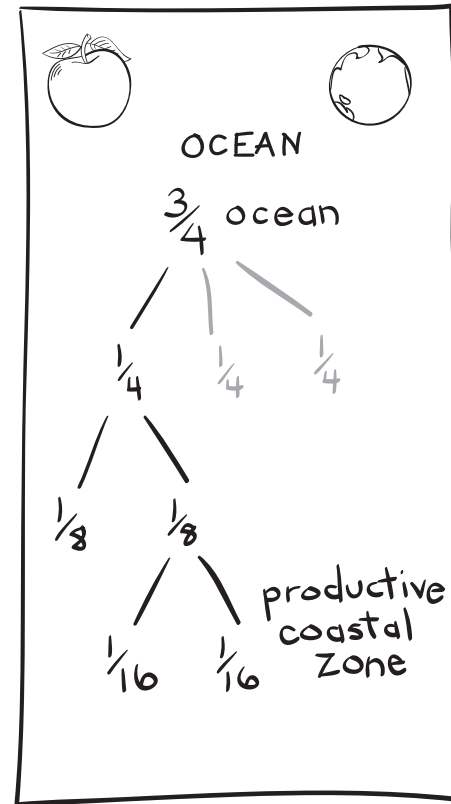

For more information on upwelling, or to add a special "Going Further" session on this topic, see page 32 following this session.

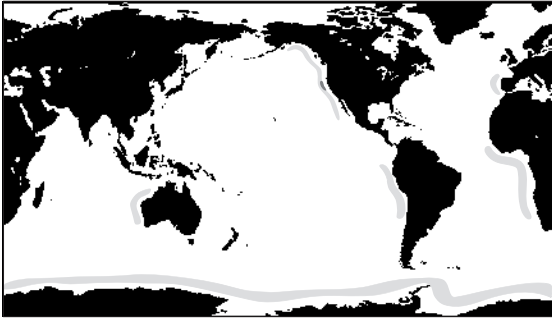

One of these upwelling areas is found along the Pacific coast of North America, making that stretch one of the biologically richest regions of the ocean. Roughly one-fourth of the entire world's upwelling zones lie off the west coast of North America between Canada and Baja California, Mexico. Along that coast, the Central California portion is by far the most biologically productive.

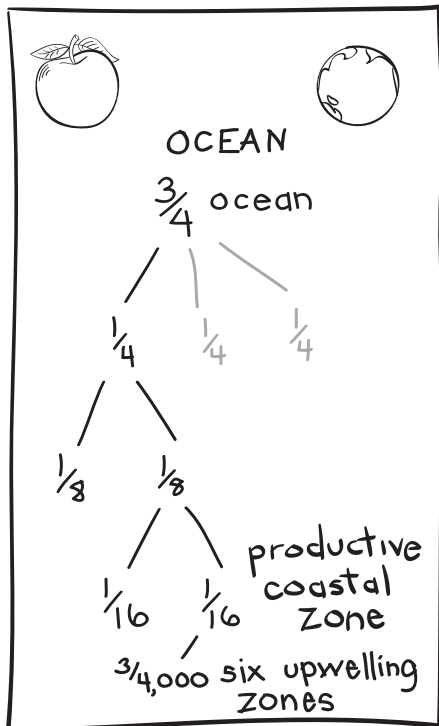

4. Teacher draws on the globe.

On the globe (using a water-based marker) draw a narrow band along the Pacific coast of North America to illustrate how small this upwelling zone is. Highlight the Central California coast as an even smaller subset. Mark the other five major upwelling areas on the planet: along the central and southwest coast of Africa; the central west coast of South America; the west coast of Australia; the west coast of Europe (Spain and Portugal); and around Antarctica. We're responsible for caring for and sharing this huge and vital world resource.

5. Teacher draws on the circle graph.

Demonstrate how to represent the rich upwelling zones on the circle graph, using six small dots (of another single color) within the productive coastal zone. With an arrow, label them " $\frac{3}{4,000}$ Six Upwelling Zones." Your circle graph is now complete.

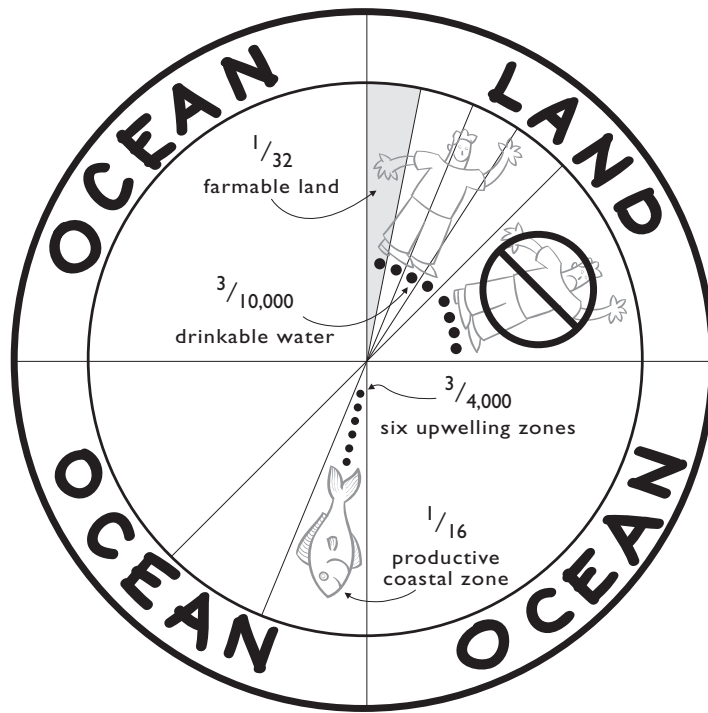

6. Students draw on the circle graph.

7. Teacher writes on the poster or transparency.

On the poster or transparency, under $\frac{1}{16}$ Productive Coastal Zone, add a branch labeled " $\frac{3}{4,000}$ —Six Upwelling Zones."

Note: At this point, some teachers like to introduce the concept of the **photic zone**, as follows: Peel off a piece of the apple skin to represent part of the ocean, and hold it up. This piece of skin, though it's too thick to be truly accurate, represents the **photic zone**—the top 100 meters (330 feet) through which light can penetrate and support photosynthesis for microscopic plantlike organisms (phytoplankton). Since these organisms form the base of the ocean food pyramid, **all** life in the ocean depends on the existence of a productive photic zone. Show the photic zone of the ocean on the graph as a (single-colored) dot or two in each of the three sections of the ocean (not shown in circle graph illustration). Label these dots: "Photic Zone." (See sidebar.)

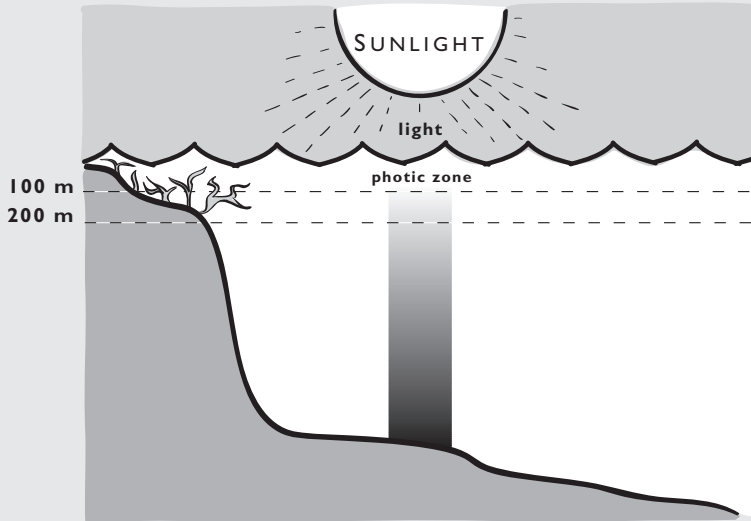

Almost all life in the ocean is concentrated in the shallow region just below the surface in a narrow band along the coasts.

Photosynthesis occurs across the entire ocean—but near the coasts, where the water is relatively shallow, the photic zone can extend all the way to the ocean floor. This provides enough sunlight for large seaweed—which anchors on the sea floor—to photosynthesize and grow. It's also along the coastlines that sunlight, carbon dioxide and oxygen, and sufficient nutrients (both from land runoff and from upwelling) combine to provide all the ingredients for phytoplankton to thrive. The rate of photosynthesis—and therefore productivity—is greatest here.

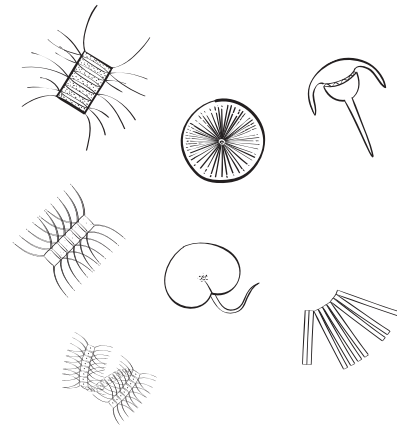

Phytoplankton

Wrap-Up

1. Have students hold up the two tiniest slices they saved. One sliver represents our **drinkable water**, the resource necessary for all life on land; the other represents all the **upwelling zones**, among the most productive places on Earth. Compare these two slivers to the whole apple. Ask, "What does the comparison of these slices to the whole apple tell you about these resources?" [These two minuscule pieces of our planet support nearly all of its life. They also represent the parts of the land and ocean that humans come in contact with, use, and affect the most. These two critical resources need to be protected to ensure a healthy future for our planet.]

2. Invite students to eat their apples as they begin to clean up. Let them know that since there's so little farmable land on which to grow all our food, you don't want to just throw away the uneaten apples. Ask, "What are other ways we could reuse these apples?" [Feed to animals, place in compost, etc.]

3. Assign students to collect each of the items they've been using (ocean pictures, markers, knives, apple pieces, paper towels). Give any uneaten apple pieces to students who offer to recycle them.

This is how your circle graph will look after all the sections have been added.

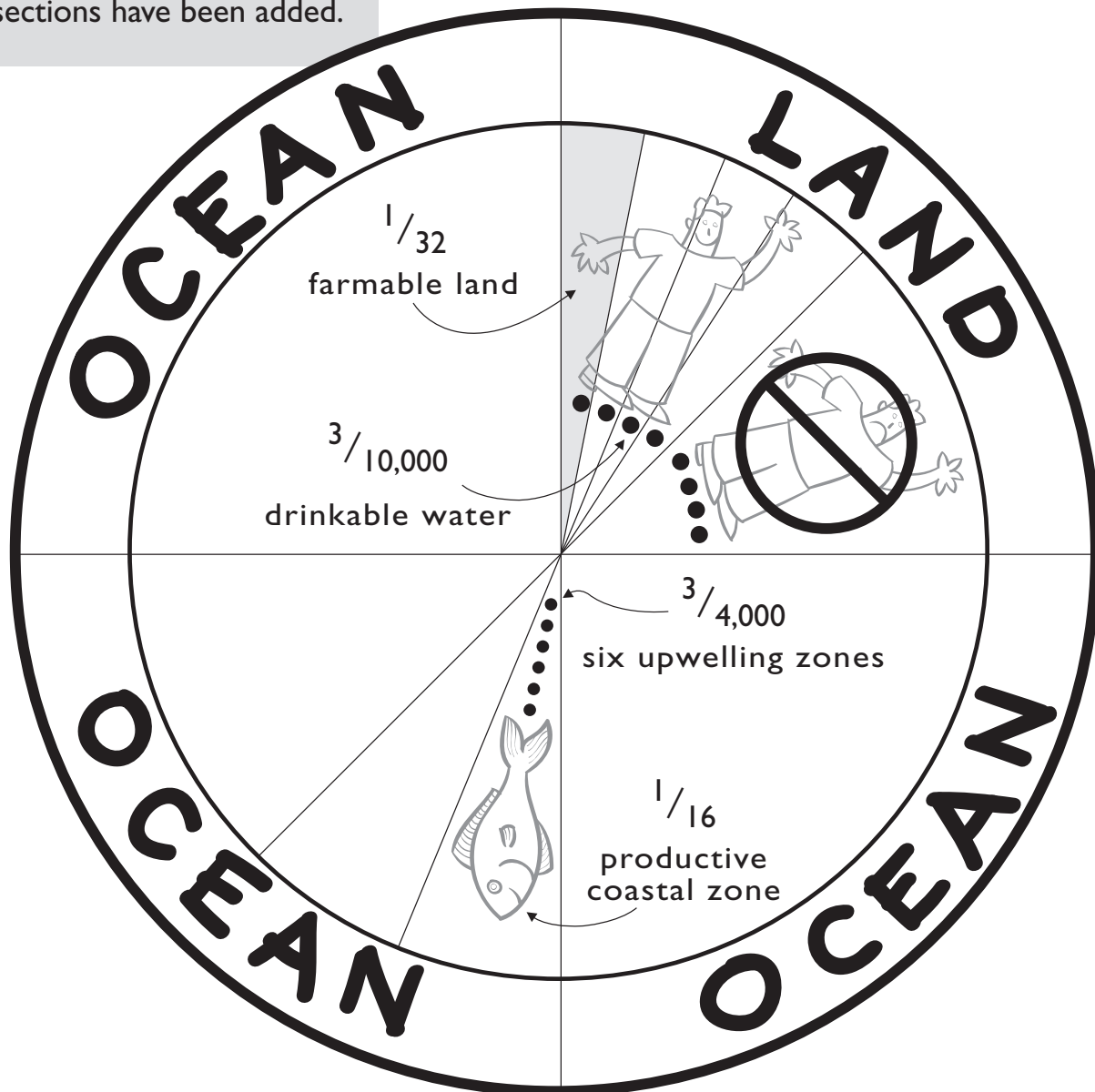

Think, Pair, Share: What Did We Learn?

Participating in a Think, Pair, Share activity allows students “think time” to formulate their own ideas and jot them down as notes. This gives all students, even those reticent to answer questions, the opportunity to organize their thoughts before hearing the answer from a classmate. This activity structure also allows the students to try out their ideas in progressively “less safe” settings: first with one partner, in the “safest” setting; then with a small group; and finally with the class.

1. Tell students that they’ve learned a *lot* about our planet, and it might be easy to forget some of the details if we don’t review them. Ask students to take a moment to “**Think**” of the things that most surprised or interested them about “Planet Ocean” and have them write down as many as they can (at least three).
2. Next, have students “**Pair**” with a partner and “**Share**” their notes with each other.
3. Have each pair create a list of five new things they learned about the land, the ocean, or the planet as a whole.
4. Initiate a class brainstorm for sharing the lists. As students share their ideas with the class, record their thoughts on the class Brainstorm Chart for Session 2 (or overhead transparency); add new sheets as necessary. As you’re writing, pairs should add new items from other pairs’ lists to their own. Compare the new chart with the original class Brainstorm Chart from Session 1.
5. In closing this session, hold up the Key Concept for this activity and have one or more students read it aloud:

- **Most of our planet is covered by ocean, but only a small fraction of the ocean supports large concentrations of life.**

Briefly discuss how this statement reviews the important ideas from today’s activities. Post the concept on the wall for students to revisit during the rest of the unit.

